

SB16C1058



Octal UART with 256-byte TX/RX FIFOs

SB16C1058 is a OCTAL UART(Universal Asynchronous Receiver/Transmitter) with 256-byte FIFOs, automatic hardware/software flow control, and data rates up to 5 Mbps. 256-byte FIFOs reduce CPU overhead and allow higher data rates and data throughput. It has a GICR(Global Interrupt Control Register)/GISR(Global Interrupt Status Register) that reduces interrupt signal control logic. Also an internal loop-back capability allows on-board diagnostics. Especially SB16C1058 have the MIO Bus control logics and it enables to extend the port number up to 32 without any glue-logics using the MIO Bus. SB16C1058 is available in TQFP128 (20x20 body) package.

■ SB16C1058 Features

- **Eight independent UART with TX/RX FIFO of 256-bytes (Deep FIFO)**
- **Data rates of up to 5Mbps**
- **Built-In SystemBase's MIO control logic and registers**
- **Extendable to 32-port Serial Multiport without any glue-logics**
- Software / Hardware flow control (Xon/Xoff & Auto-RTS/Auto-CTS)
- **Global interrupt Mask/Poll register**
- **Supports Xoff re-transmit & Xon-any character**
- **Dedicated Control Pins for RS422/485 Auto Toggling**
- **Fast UART Response Time, 24ns for IOR & IOW operation**
- **Fast Service using Global Interrupt and Interrupt Vector Processing**
- Sleep mode (low operating current)
- 3.3V I/O and 5V Tolerance, 128-pin TQFP (20x20 body)

● Application

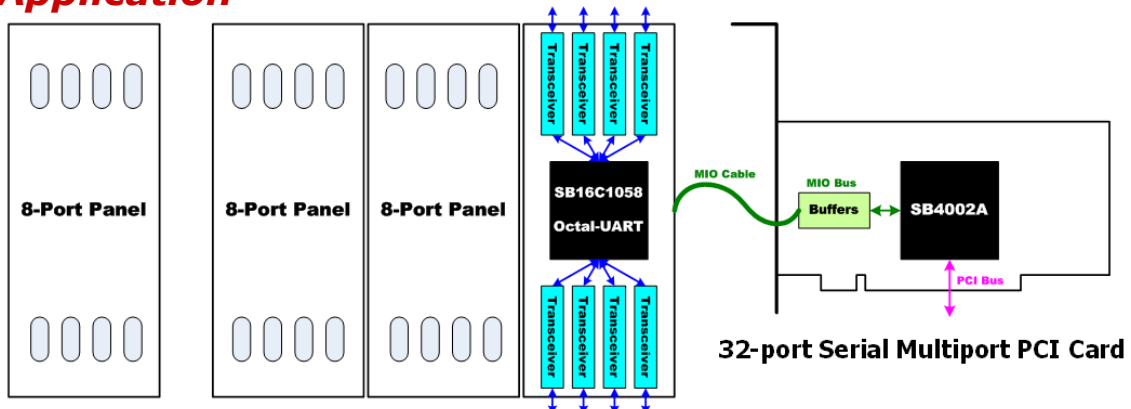

© 2008 SystemBase Co., Ltd.

16th Fl. Daerung Post Tower-1, 212-8, Guro-dong, Guro-gu, Seoul, Korea

Tel +82-2-855-0501 | Fax +82-2-855-0580 | marketing@sysbas.com | www.sysbas.com

Specifications subject to change without notice

SystemBase

Block Diagram

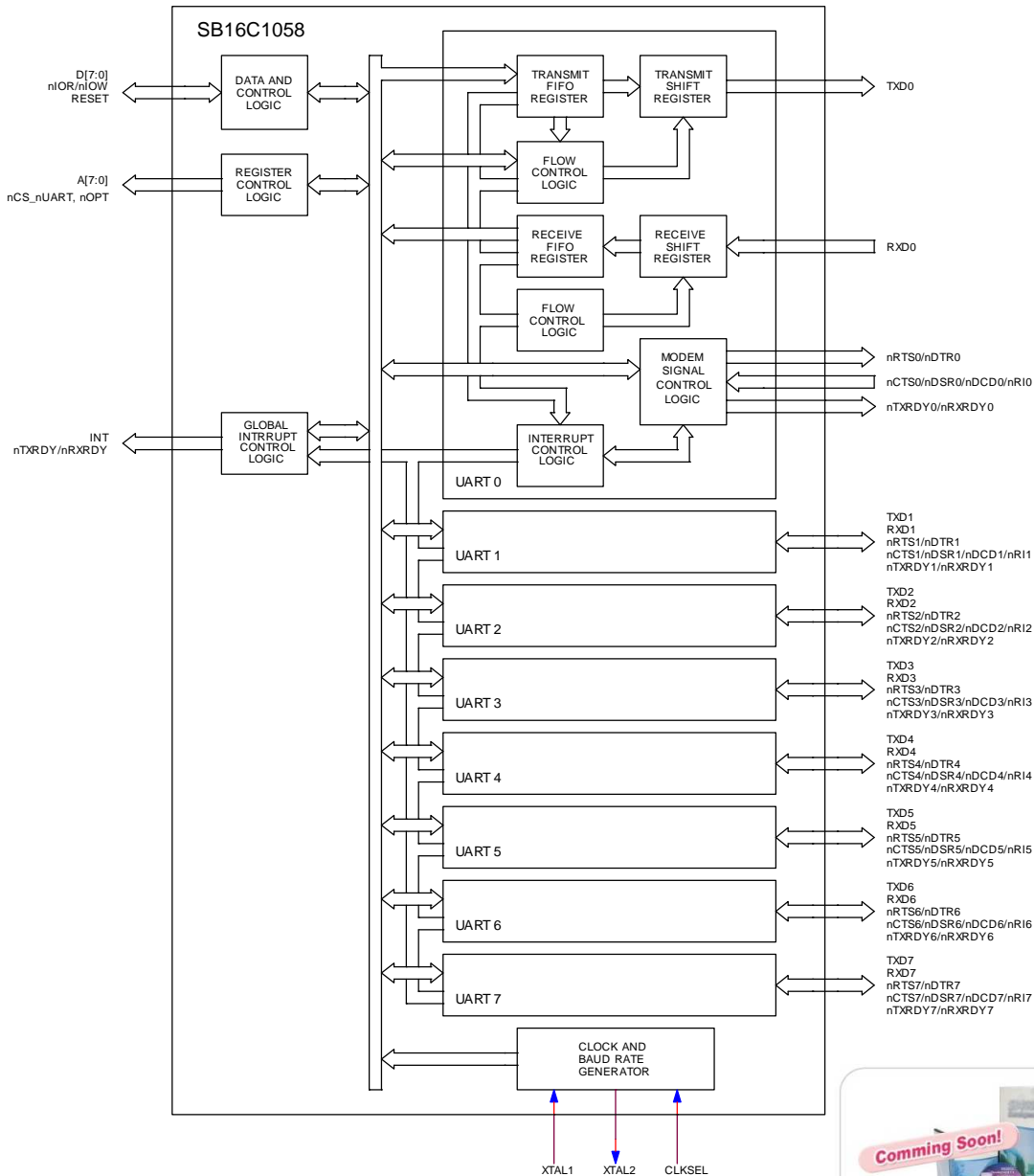

Ordering Information

SystemBase provides users with an SB16C1058 development tool, which can cut down both cost and effort as much as possible while securing safety in product development. The SB16C1058 development tool offers H/W circuit diagrams, CAD files, S/W device drivers and source codes. With these, you can lay out new device in an easier and faster way.

Products	Description
SB16C1058-TQ	Octal-UART with 256-byte TX/RX FIFO, 128-pin TQFP (20x20) Package
SB16C1058 Development Kit	Evaluation Board, Data Sheet, Development Kit Manual, Development Kit CD - E/B Schematics - E/B Artwork & Gerber - Device Driver & Test Program - Source Code

© 2008 SystemBase Co., Ltd.

16th Fl. Daerung Post Tower-1, 212-8, Guro-dong, Guro-gu, Seoul, Korea

Tel +82-2-855-0501 | Fax +82-2-855-0580 | marketing@sysbas.com | www.sysbas.com

Specifications subject to change without notice

SystemBase