

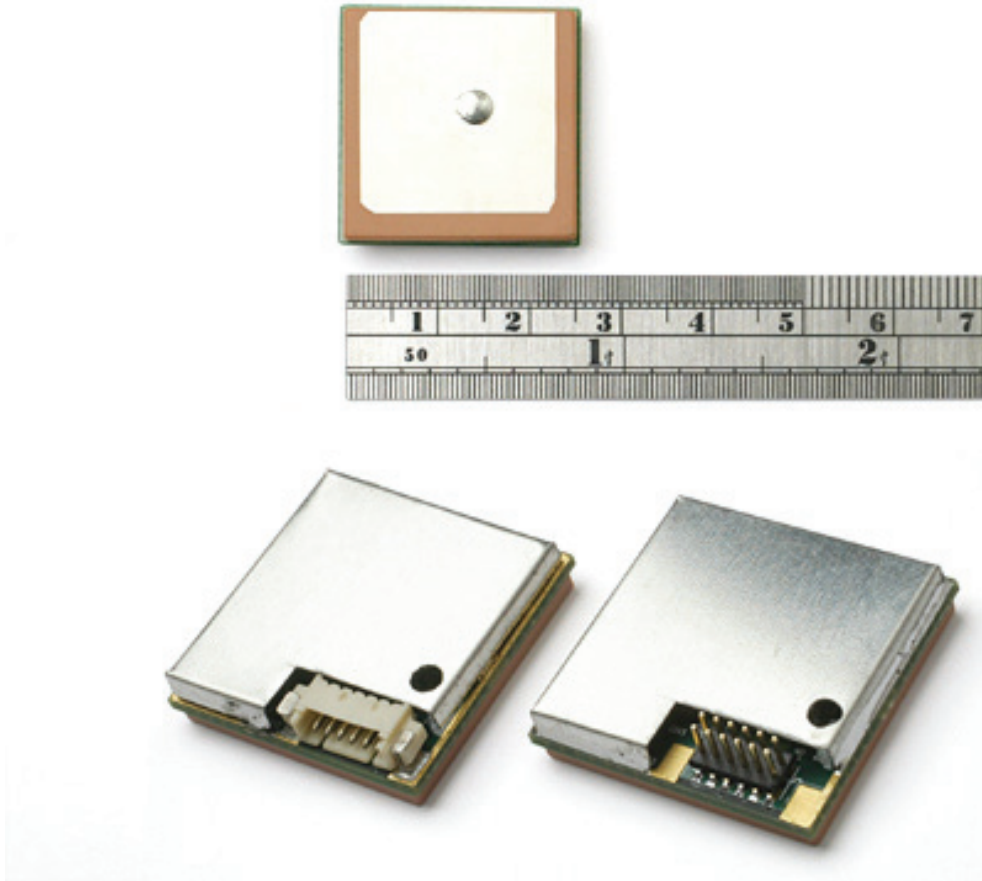

FGPMMOPA2 Datasheet

Rev.A07



51-channel GPS Engine Board SmartAntenna

with MTK Chipset

FGPMMOPA2

The document is the exclusive property of GlobalTop Tech Inc. and should not be distributed, reproduced, or any other format without prior permission of GlobalTop Tech Inc. Specifications subject to change without prior notice

GlobalTop Tech Inc.

No.16 Nan-ke 9th Rd, Science-Based Industrial Park, Tainan, 741, Taiwan, R.O.C.
Tel:+886-6-5051268 Fax:+886-6-5053381 <http://www.gtop-tech.com/> email: sales@gtop-tech.com
Copyright© 2007 GlobalTop Tech Inc. All right reserved.



FGPMMOPA2 Datasheet

Rev.A07

History		
Date	Rev.	Description
2007/04/17	A00	First Release
2007/05/25	A01	1. Add DC Characteristics 2. Modify Pin Description 3. Delete "LED Indication of GPS Fix Mode"
2008/03/27	A02	1. Add "LED Indication of GPS Fix Mode" 2. Modified NMEA Output Sentence
2008/06/12	A03	Revise : Operation supply Voltage : 3.3V~5.5V ---> 3.0V~3.6V
2008/12/15	A04	Modify Operating Temperature Range
2010/3/23	A05	Add Packing and Handling Section
2010/04/30	A06	Page17: Modify for RMC Magnetic Variation data
2011/05/13	A07	Update company contact information

The document is the exclusive property of GlobalTop Tech Inc. and should not be distributed, reproduced, or any other format without prior permission of GlobalTop Tech Inc. Specifications subject to change without prior notice

GlobalTop Tech Inc.

No.16 Nan-ke 9th Rd, Science-Based Industrial Park, Tainan, 741, Taiwan, R.O.C.
Tel:+886-6-5051268 Fax:+886-6-5053381 <http://www.gtop-tech.com/> email: sales@gtop-tech.com
Copyright© 2007 GlobalTop Tech Inc. All right reserved.



FGPMMOPA2 Datasheet

Rev.A07

Description

The FGPMMOPA2 is a POT (Patch On Top) GPS second generation module. It is more compact in size than the first generation. This POT GPS receiver provides a solution that is high in position and speed accuracy performances, with high sensitivity and tracking capabilities in urban conditions. The GPS chipset inside the module is designed by **MediaTek Inc.**, the world's leading digital media solution provider and the largest fab-less IC company in Taiwan. The module can support up to **51 channels**. This GPS solution enables small form factor devices. It delivers major advancements in GPS performances, accuracy, integration, computing power and flexibility. FGPMMOPA2 is designed to simplify the embedded system integration process.

FGPMMOPA2 Features

- ✿ Based on **MediaTek Single Chip** Architecture
- ✿ Dimension: 26mm x 26mm x 5.5mm
- ✿ Patch Antenna Size: 25mm x 25mm x 2mm
- ✿ Low Power Consumption: **62mA @ acquisition, 46mA @ tracking**
- ✿ L1 Frequency, C/A code, **51-channel**
- ✿ High Sensitivity: Up to -158 dBm tracking, superior urban performances¹
- ✿ Position Accuracy: Without aid: 3m 2D-RMS
DGPS (RTM,SBAS(WAAS,EGNOS,MASA)):2.5m 2D-RMS
- ✿ Cold Start is under 36 seconds (Typical)¹
- ✿ Warm Start is under 33 seconds (Typical)¹
- ✿ Hot Start is under 1 second (Typical)¹
- ✿ Data output Baud rate: 9600 bps
- ✿ Max. Update Rate: **5Hz (Default: 1Hz)**
- ✿ RoHS Compliant
- ✿ Optional in connecting interface pin header
(**Connector Type: PA2-C or Pin-header Type: PA2-P**)

¹ Reference to GPS chipset specification



FGPMMOPA2 Datasheet

Rev.A07

System Block

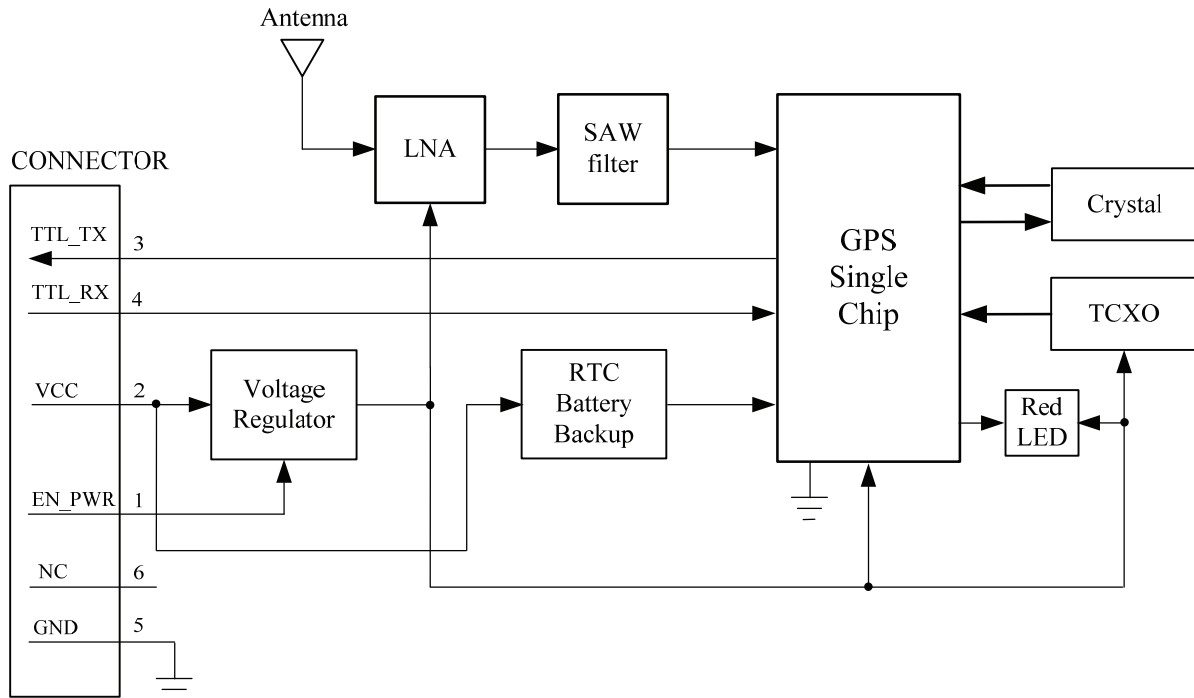

The document is the exclusive property of GlobalTop Tech Inc. and should not be distributed, reproduced, or any other format without prior permission of GlobalTop Tech Inc. Specifications subject to change without prior notice

GlobalTop Tech Inc.

No.16 Nan-ke 9th Rd, Science-Based Industrial Park, Tainan, 741, Taiwan, R.O.C.
Tel:+886-6-5051268 Fax:+886-6-5053381 <http://www.gtop-tech.com/> email: sales@gtop-tech.com
Copyright© 2007 GlobalTop Tech Inc. All right reserved.



FGPMMOPA2 Datasheet

Rev.A07

Mechanical and Pin Configuration

Item	Model Name	Description
1	FGPMMOPA2-C	Wire to Board Header
2	FGPMMOPA2-P	Pin Header, Dual Row

1. Model Name: FGPMMOPA2-C

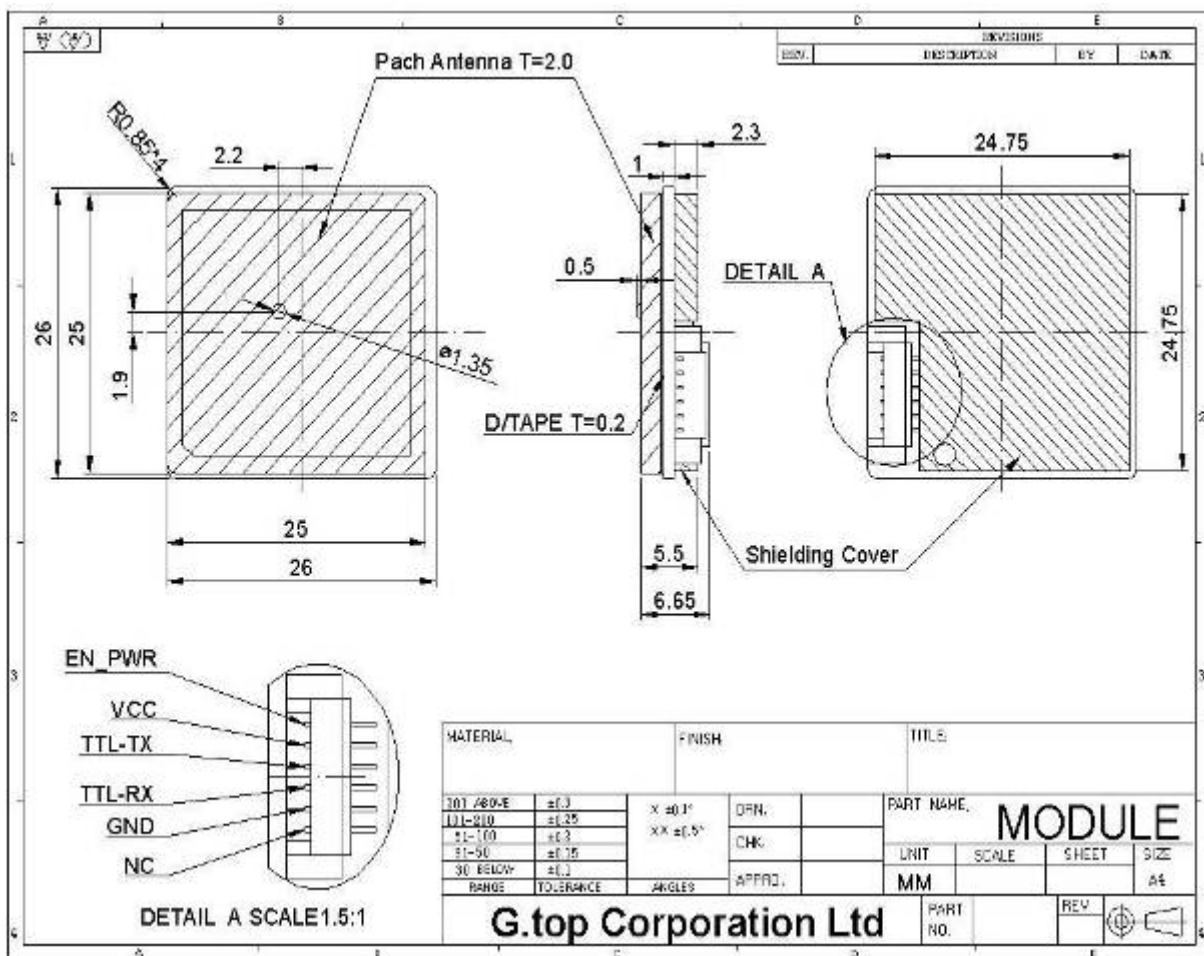

The document is the exclusive property of GlobalTop Tech Inc. and should not be distributed, reproduced, or any other format without prior permission of GlobalTop Tech Inc. Specifications subject to change without prior notice

GlobalTop Tech Inc.

No.16 Nan-ke 9th Rd, Science-Based Industrial Park, Tainan, 741, Taiwan, R.O.C.
 Tel:+886-6-5051268 Fax:+886-6-5053381 <http://www.gtop-tech.com/> email: sales@gtop-tech.com
 Copyright© 2007 GlobalTop Tech Inc. All right reserved.



FGPMMOPA2 Datasheet

Rev.A07

2. Model Name: FGPMMOPA2-P

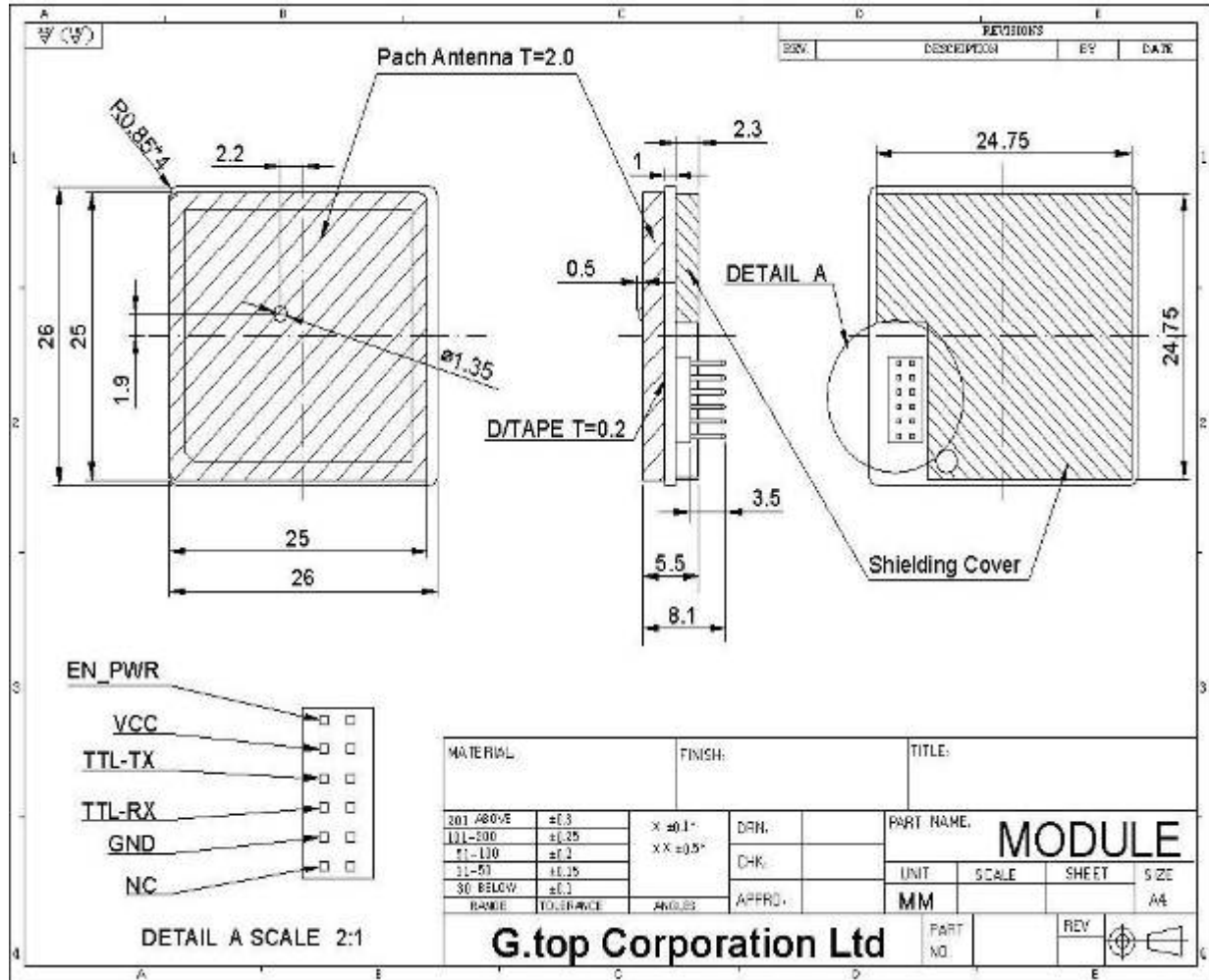

The document is the exclusive property of GlobalTop Tech Inc. and should not be distributed, reproduced, or any other format without prior permission of GlobalTop Tech Inc. Specifications subject to change without prior notice

GlobalTop Tech Inc.

No.16 Nan-ke 9th Rd, Science-Based Industrial Park, Tainan, 741, Taiwan, R.O.C.
 Tel:+886-6-5051268 Fax:+886-6-5053381 <http://www.gtop-tech.com/> email: sales@gtop-tech.com
 Copyright© 2007 GlobalTop Tech Inc. All right reserved.



FGPMMOPA2 Datasheet

Rev.A07

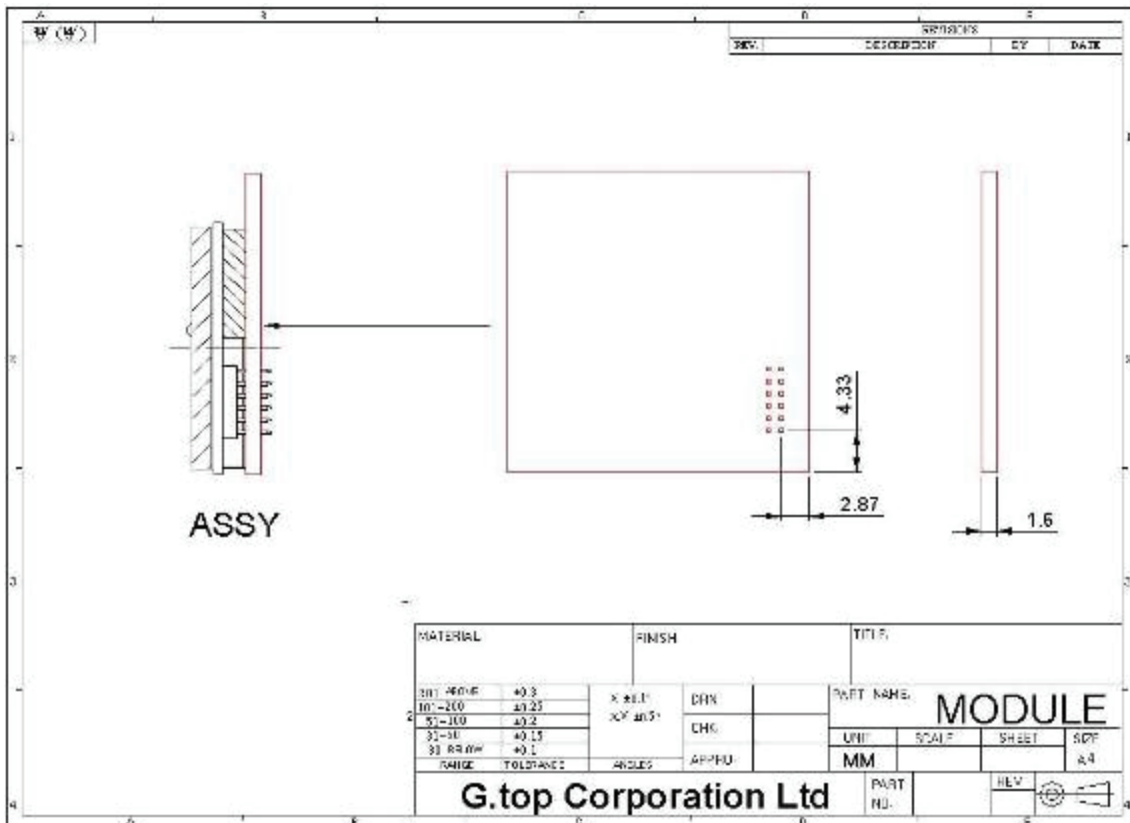

For the mechanical of this header and its corresponding connector, please see Appendix for details.

The document is the exclusive property of GlobalTop Tech Inc. and should not be distributed, reproduced, or any other format without prior permission of GlobalTop Tech Inc. Specifications subject to change without prior notice

GlobalTop Tech Inc.

No.16 Nan-ke 9th Rd, Science-Based Industrial Park, Tainan, 741, Taiwan, R.O.C.
 Tel:+886-6-5051268 Fax:+886-6-5053381 <http://www.gtop-tech.com/> email: sales@gtop-tech.com
 Copyright© 2007 GlobalTop Tech Inc. All right reserved.



FGPMMOPA2 Datasheet

Rev.A07

Pin Definition

Pin	Name	I/O	Description
1	EN_PWR	I	Enable Power
2	VCC	P	DC Power Input
3	TTL-TX	O	Serial Data Output
4	TTL-RX	I	Serial Data Input
5	GND	P	Ground
6	NC		Not Connection

Description of I/O Pin

EN-PWR (Pin1)

It is low active. You may shut down the module by applying high logic level.

VCC (Pin2)

The DC power supply of the module

TTL-TX (Pin3)

This is the UART transmitter of the module. It outputs the GPS information for application.

TTL-RX (Pin4)

This is the UART receiver of the module. It is used to receive software commands and firmware update.

GND (Pin5)

Ground

NC (Pin6)

This pin is not connection.

The document is the exclusive property of GlobalTop Tech Inc. and should not be distributed, reproduced, or any other format without prior permission of GlobalTop Tech Inc. Specifications subject to change without prior notice

GlobalTop Tech Inc.

No.16 Nan-ke 9th Rd, Science-Based Industrial Park, Tainan, 741, Taiwan, R.O.C.
Tel:+886-6-5051268 Fax:+886-6-5053381 <http://www.gtop-tech.com/> email: sales@gtop-tech.com
Copyright© 2007 GlobalTop Tech Inc. All right reserved.



FGPMMOPA2 Datasheet

Rev.A07

LED Indication of GPS Fix mode

The LED indication on the module was assigned as fix flag output.

- Before 2D Fix

The LED indication should continuously output one-second brightness and one-second darkness.

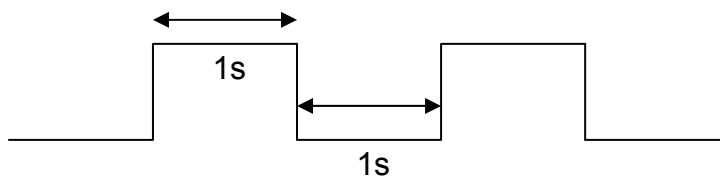

- After 2D or 3D Fix

The LED indication should continuously output brightness.

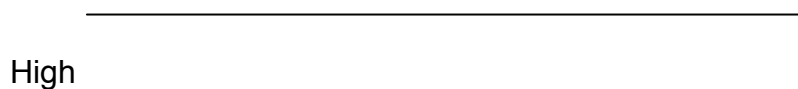

The document is the exclusive property of GlobalTop Tech Inc. and should not be distributed, reproduced, or any other format without prior permission of GlobalTop Tech Inc. Specifications subject to change without prior notice

GlobalTop Tech Inc.

No.16 Nan-ke 9th Rd, Science-Based Industrial Park, Tainan, 741, Taiwan, R.O.C.
Tel:+886-6-5051268 Fax:+886-6-5053381 <http://www.gtop-tech.com/> email: sales@gtop-tech.com
Copyright© 2007 GlobalTop Tech Inc. All right reserved.



FGPMMOPA2 Datasheet

Rev.A07

Specifications

General	
Chipset	MTK MT3318
Frequency	L1, 1575.42MHz
C/A Code	1.023 MHz
Channels	51 channels
DGPS	RTCM protocol WAAS, EGNOS, MSAS
Datum	WGS84(Default), Tokyo-M, Tokyo-A, User Define
CPU	ARM7TDMI
Dimensions	
Length/Width/Height	26mm x 26mm x 5.5mm
Weight	8g
Performance Characteristics	
Position Accuracy	Without aid: 3m 2D-RMS
	DGPS(RTM,SBAS(WAAS,EGNOS,MASA)):2.5m 2D-RMS
Velocity Accuracy	Without aid:0.1 m/s
	DGPS (RTCM, SBAS (WAAS, EGNOS, MSAS)):0.05m/s
Acceleration	Without aid:< 4g
	DGPS (RTCM, SBAS (WAAS, EGNOS, MSAS)):< 4g
Timing Accuracy	100 ns RMS
Sensitivity ¹	Acquisition:-146dBm (Cold Start)
	Reacquisition:-156dBm
	Tracking:-158dBm
Max. Update Rate	5Hz (Default: 1Hz)

The document is the exclusive property of GlobalTop Tech Inc. and should not be distributed, reproduced, or any other format without prior permission of GlobalTop Tech Inc. Specifications subject to change without prior notice

GlobalTop Tech Inc.

No.16 Nan-ke 9th Rd, Science-Based Industrial Park, Tainan, 741, Taiwan, R.O.C.
Tel:+886-6-5051268 Fax:+886-6-5053381 <http://www.gtop-tech.com/> email: sales@gtop-tech.com
Copyright© 2007 GlobalTop Tech Inc. All right reserved.



FGPMMOPA2 Datasheet

Rev.A07

Acquisition (Open sky, stationary)	
Reacquisition Time ¹	Less than 1 second
Hot start ¹	1 second (Typical)
Warm start ¹	33 seconds (Typical)
Cold start ¹	36 seconds (Typical)
Dynamic	
Altitude	Maximum 18,000m
Velocity	Maximum 515m/s
Acceleration	Maximum 4g
I/O	
Signal Output	8 data bits, no parity, 1 stop bit
Available Baud Rates	9600 bps (Default) (4800/14400/19200/38400/57600/115200 is also available)
Protocols	NMEA 0183 v3.01 (Default: GGA,GSA,GSV,RMC,VTG) RTCM MTK NMEA Command Network Assistance Messages
Data output Interface	
Protocol messages	9600 bps/8/N/1 (Default)
Output format	GGA(1sec),GSA(1sec),RMC(1sec),VTG(1sec), GSV(5sec) (Default)
Environment	
Operating Temperature	-40°C to 85 °C (without coin battery) -20°C to 60 °C (with coin battery)
Storage Temperature	-50°C to 90 °C (without coin battery) -20°C to 60 °C (with coin battery)
Operating Humidity	5% to 95% (no condensing)

¹ Reference to GPS chipset specification

The document is the exclusive property of GlobalTop Tech Inc. and should not be distributed, reproduced, or any other format without prior permission of GlobalTop Tech Inc. Specifications subject to change without prior notice

GlobalTop Tech Inc.

No.16 Nan-ke 9th Rd, Science-Based Industrial Park, Tainan, 741, Taiwan, R.O.C.
Tel:+886-6-5051268 Fax:+886-6-5053381 <http://www.gtop-tech.com/> email: sales@gtop-tech.com
Copyright© 2007 GlobalTop Tech Inc. All right reserved.



FGPMMOPA2 Datasheet

Rev.A07

DC Characteristics

Parameter	Condition	Min.	Typ.	Max.	Unit
Operation supply Voltage	VCC	3.0	3.3	3.6	V
Operation supply Ripple Voltage	—	—	—	50	mVpp
RXA TTL H Level	VCC=3.3V	2.1	—	VCC	V
RXA TTL L Level	VCC=3.3V	0	—	0.9	V
TXA TTL H Level	VCC=3.3V	2.1	—	2.8	V
TXA TTL L Level	VCC=3.3V	0	—	0.8	V
Power Consumption @ 3.3V	Acquisition	57	62	67	mA
	Tracking	41	46	51	mA

The document is the exclusive property of GlobalTop Tech Inc. and should not be distributed, reproduced, or any other format without prior permission of GlobalTop Tech Inc. Specifications subject to change without prior notice

GlobalTop Tech Inc.

No.16 Nan-ke 9th Rd, Science-Based Industrial Park, Tainan, 741, Taiwan, R.O.C.
Tel:+886-6-5051268 Fax:+886-6-5053381 <http://www.gtop-tech.com/> email: sales@gtop-tech.com
Copyright© 2007 GlobalTop Tech Inc. All right reserved.



FGPMMOPA2 Datasheet

Rev.A07

NMEA Output Sentence

Table-1 lists each of the NMEA output sentences specifically developed and defined by MTK for use within MTK products

NMEA Output Sentence		Table-1
Option	Description	
GGA	Time, position and fix type data.	
GSA	GPS receiver operating mode, active satellites used in the position solution, and DOP values.	
GSV	The number of GPS satellites in view satellite ID numbers, elevation, azimuth, and SNR values.	
RMC	Time, date, position, course and speed data. Recommended Minimum Navigation Information.	
VTG	Course and speed information relative to the ground.	

The document is the exclusive property of GlobalTop Tech Inc. and should not be distributed, reproduced, or any other format without prior permission of GlobalTop Tech Inc. Specifications subject to change without prior notice

GlobalTop Tech Inc.

No.16 Nan-ke 9th Rd, Science-Based Industrial Park, Tainan, 741, Taiwan, R.O.C.
Tel:+886-6-5051268 Fax:+886-6-5053381 <http://www.gtop-tech.com/> email: sales@gtop-tech.com
Copyright© 2007 GlobalTop Tech Inc. All right reserved.



FGPMMOPA2 Datasheet

Rev.A07

GGA—Global Positioning System Fixed Data. Time, Position and fix related data for a GPS receiver

Table-2 contains the values for the following example:

\$GPGGA,011528.000,2307.1203,N,12016.4430,E,1,7,1.11,18.3,M,17.8,M,,*6F

GGA Data Format			Table-2
Name	Example	Units	Description
Message ID	\$GPGGA		GGA protocol header
UTC Time	011528.000		hhmmss.sss
Latitude	2307.1203		ddmm.mmmm
N/S Indicator	N		N=north or S=south
Longitude	12016.4430		dddmm.mmmm
E/W Indicator	E		E=east or W=west
Position Fix Indicator	1		See Table-3
Satellites Used	7		Range 0 to 14
HDOP	1.11		Horizontal Dilution of Precision
MSL Altitude	18.3	meters	Antenna Altitude above/below mean-sae-level
Units	M	meters	Units of antenna altitude
Geoidal Separation	17.8	meters	
Units	M	meters	Units of geoidal separation
Age of Diff. Corr.		second	Null fields when DGPS is not used
Checksum	*6F		
<CR> <LF>			End of message termination

Position Fix Indicator		Table-3
Value	Description	
0	Fix not available	
1	GPS fix	
2	Differential GPS fix	

The document is the exclusive property of GlobalTop Tech Inc. and should not be distributed, reproduced, or any other format without prior permission of GlobalTop Tech Inc. Specifications subject to change without prior notice

GlobalTop Tech Inc.

No.16 Nan-ke 9th Rd, Science-Based Industrial Park, Tainan, 741, Taiwan, R.O.C.
 Tel:+886-6-5051268 Fax:+886-6-5053381 <http://www.gtop-tech.com/> email: sales@gtop-tech.com
 Copyright© 2007 GlobalTop Tech Inc. All right reserved.



FGPMMOPA2 Datasheet

Rev.A07

GSA—GNSS DOP and Active Satellites

Table-4 contains the values for the following example:

\$GPGSA,A,3,23,05,13,04,17,12,10,,,,,1.44,1.11,0.92*0F

GSA Data Format			Table-4
Name	Example	Units	Description
Message ID	\$GPGSA		GSA protocol header
Mode 1	A		See Table-5
Mode 2	3		See Table-6
Satellite Used	23		SV on Channel 1
Satellite Used	05		SV on Channel 2
....
Satellite Used			SV on Channel 12
PDOP	1.44		Position Dilution of Precision
HDOP	1.11		Horizontal Dilution of Precision
VDOP	0.92		Vertical Dilution of Precision
Checksum	*0F		
<CR> <LF>			End of message termination

Mode 1		Table-5
Value	Description	
M	Manual—forced to operate in 2D or 3D mode	
A	2D Automatic—allowed to automatically switch 2D/3D	

Mode 2		Table-6
Value	Description	
1	Fix not available	
2	2D (< 4 SVs used)	
3	3D (\geq 4 SVs used)	

The document is the exclusive property of GlobalTop Tech Inc. and should not be distributed, reproduced, or any other format without prior permission of GlobalTop Tech Inc. Specifications subject to change without prior notice

GlobalTop Tech Inc.

No.16 Nan-ke 9th Rd, Science-Based Industrial Park, Tainan, 741, Taiwan, R.O.C.
 Tel:+886-6-5051268 Fax:+886-6-5053381 <http://www.gtop-tech.com/> email: sales@gtop-tech.com
 Copyright© 2007 GlobalTop Tech Inc. All right reserved.



FGPMMOPA2 Datasheet

Rev.A07

GSV—GNSS Satellites in View

Table-7 contains the values for the following example:

\$GPGSV,2,1,08,17,52,126,47,04,49,015,49,10,40,238,46,13,34,071,46*7A

\$GPGSV,2,2,08,12,20,299,43,23,13,046,45,05,12,304,44,02,,,48*4A

GSV Data Format			Table-7
Name	Example	Units	Description
Message ID	\$GPGSV		GSV protocol header
Number of Messages	2		Range 1 to 3 <i>(Depending on the number of satellites tracked, multiple messages of GSV data may be required.)</i>
Message Number1	1		Range 1 to 3
Satellites in View	08		
Satellite ID	17		Channel 1 (Range 1 to 32)
Elevation	52	degrees	Channel 1 (Maximum 90)
Azimuth	126	degrees	Channel 1 (True, Range 0 to 359)
SNR (C/No)	47	dBHz	Range 0 to 99, (null when not tracking)
....
Satellite ID	13		Channel 4 (Range 1 to 32)
Elevation	34	degrees	Channel 4 (Maximum 90)
Azimuth	071	degrees	Channel 4 (True, Range 0 to 359)
SNR (C/No)	46	dBHz	Range 0 to 99, (null when not tracking)
Checksum	*7A		
<CR> <LF>			End of message termination

The document is the exclusive property of GlobalTop Tech Inc. and should not be distributed, reproduced, or any other format without prior permission of GlobalTop Tech Inc. Specifications subject to change without prior notice

GlobalTop Tech Inc.

No.16 Nan-ke 9th Rd, Science-Based Industrial Park, Tainan, 741, Taiwan, R.O.C.
Tel:+886-6-5051268 Fax:+886-6-5053381 <http://www.gtop-tech.com/> email: sales@gtop-tech.com
Copyright© 2007 GlobalTop Tech Inc. All right reserved.



FGPMMOPA2 Datasheet

Rev.A07

RMC—Recommended Minimum Navigation Information

Table-8 contains the values for the following example:

\$GPRMC,011528.000,A,2307.1203,N,12016.4430,E,0.21,198.97,170407,3.05,W,A*5A

RMC Data Format			Table-8
Name	Example	Units	Description
Message ID	\$GPRMC		RMC protocol header
UTC Time	011528.000		hhmmss.sss
Status	A		A=data valid or V=data not valid
Latitude	2307.1203		ddmm.mmmm
N/S Indicator	N		N=north or S=south
Longitude	12016.4430		dddmm.mmmm
E/W Indicator	E		E=east or W=west
Speed Over Ground	0.21	knots	
Course Over Ground	198.97	degrees	True
Date	170407		ddmmyy
Magnetic Variation	3.05, W	degrees	E=east or W=west (Need GlobalTop customization service)
Mode	A		A= Autonomous mode D= Differential mode E= Estimated mode
Checksum	*5A		
<CR> <LF>			End of message termination

The document is the exclusive property of GlobalTop Tech Inc. and should not be distributed, reproduced, or any other format without prior permission of GlobalTop Tech Inc. Specifications subject to change without prior notice

GlobalTop Tech Inc.

No.16 Nan-ke 9th Rd, Science-Based Industrial Park, Tainan, 741, Taiwan, R.O.C.
 Tel:+886-6-5051268 Fax:+886-6-5053381 <http://www.gtop-tech.com/> email: sales@gtop-tech.com
 Copyright© 2007 GlobalTop Tech Inc. All right reserved.



FGPMMOPA2 Datasheet

Rev.A07

VTG—Course and speed information relative to the ground.

Table-9 contains the values for the following example:

\$GPVTG,198.97,T,,M,0.21,N,0.39,K,A*3D

VTG Data Format			Table-9
Name	Example	Units	Description
Message ID	\$GPVTG		VTG protocol header
Course	198.97	degrees	Measured heading
Reference	T		True
Course		degrees	Measured heading
Reference	M		Magnetic <i>(Need Global Top customization service)</i>
Speed	0.21	knots	Measured horizontal speed
Units	N		Knots
Speed	0.39	km/hr	Measured horizontal speed
Units	K		Kilometers per hour
Mode	A		A= Autonomous mode D= Differential mode E= Estimated mode
Checksum	*3D		
<CR> <LF>			End of message termination

MTK NMEA Command Protocol

Packet Type:

103 PMTK_CMD_COLD_START

Packet Meaning:

Cold Start: Don't use Time, Position, Almanacs and Ephemeris data at re-start.

Example:

\$PMTK103*30<CR><LF>

The document is the exclusive property of GlobalTop Tech Inc. and should not be distributed, reproduced, or any other format without prior permission of GlobalTop Tech Inc. Specifications subject to change without prior notice

GlobalTop Tech Inc.

No.16 Nan-ke 9th Rd, Science-Based Industrial Park, Tainan, 741, Taiwan, R.O.C.
Tel:+886-6-5051268 Fax:+886-6-5053381 <http://www.gtop-tech.com/> email: sales@gtop-tech.com
Copyright© 2007 GlobalTop Tech Inc. All right reserved.



FGPMMOPA2 Datasheet

Rev.A07

Packing and Handling

GPS modules, like other electronic components, are sensitive electrostatic discharges and temperature. By following the standards outlined in this document for GlobalTop GPS module storage and handling, it is possible to reduce the chances of them being damaged during production set-up. This document will go through the basics on how GlobalTop packages its modules to ensure they arrive at their destination without any damages and deterioration to performance quality.

⚠ Please read the sections II to V carefully to avoid damages permanent damages due to moisture intake

⚠ GPS receiver modules contain highly sensitive electronic circuits and are electronic sensitive devices and improper handling without ESD protections may lead to permanent damages to the modules. Please read section VI for more details.

Packing

GlobalTop GPS modules are packed in such a way to ensure the product arrives to SMD factory floor without any damages.

GPS modules are placed individually on to the packaging tray. The trays will then be stacked and packaged together.

Included are:

1. Two packs of desiccant for moisture absorption
2. One moisture level color coded card for relative humidity percentage.

Each package is then placed inside an antistatic bag (or PE bag) that prevents the modules from being damaged by electrostatic discharge.

The document is the exclusive property of GlobalTop Tech Inc. and should not be distributed, reproduced, or any other format without prior permission of GlobalTop Tech Inc. Specifications subject to change without prior notice

GlobalTop Tech Inc.

No.16 Nan-ke 9th Rd, Science-Based Industrial Park, Tainan, 741, Taiwan, R.O.C.
Tel:+886-6-5051268 Fax:+886-6-5053381 <http://www.gtop-tech.com/> email: sales@gtop-tech.com
Copyright© 2007 GlobalTop Tech Inc. All right reserved.



FGPMMOPA2 Datasheet

Rev.A07



Figure 1: One pack of GPS modules

Each bag is then carefully placed inside two levels of cardboard carton boxes for maximum protection.



Figure 2: Box protection

The moisture color coded card provides an insight to the relative humidity percentage (RH). When the GPS modules are taken out, it should be around or lower than 30% RH level.

Outside each electrostatic bag is a caution label for moisture sensitive device.

The document is the exclusive property of GlobalTop Tech Inc. and should not be distributed, reproduced, or any other format without prior permission of GlobalTop Tech Inc. Specifications subject to change without prior notice

GlobalTop Tech Inc.

No.16 Nan-ke 9th Rd, Science-Based Industrial Park, Tainan, 741, Taiwan, R.O.C.
Tel:+886-6-5051268 Fax:+886-6-5053381 <http://www.gtop-tech.com/> email: sales@gtop-tech.com
Copyright© 2007 GlobalTop Tech Inc. All right reserved.

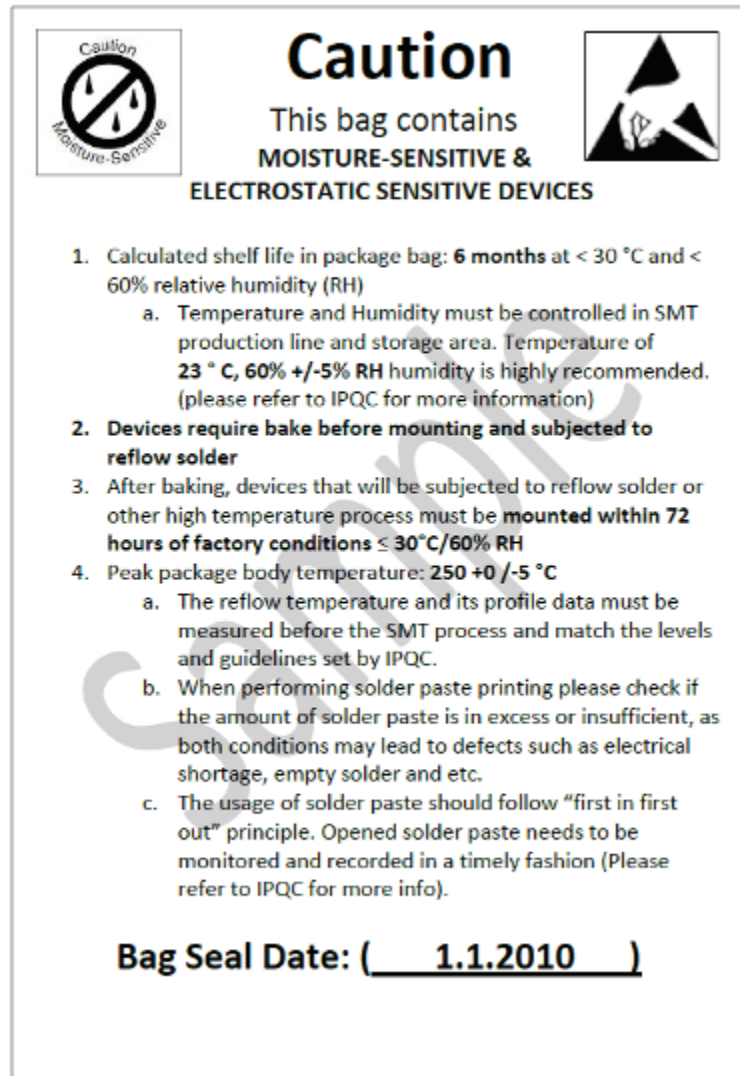

Figure 3: Example of moisture color coded card and caution label

Storage and Floor Life Guideline

The approximate shelf life for GlobalTop GPS modules packages is 6 months from the bag seal date, when store in a non-condensing storage environment (<30°C/60% RH)

⚠ It is important to note that it is a required process for GlobalTop GPS modules to undergo pre-baking procedures, regardless of the storage condition.

The document is the exclusive property of GlobalTop Tech Inc. and should not be distributed, reproduced, or any other format without prior permission of GlobalTop Tech Inc. Specifications subject to change without prior notice

GlobalTop Tech Inc.

No.16 Nan-ke 9th Rd, Science-Based Industrial Park, Tainan, 741, Taiwan, R.O.C.
Tel:+886-6-5051268 Fax:+886-6-5053381 <http://www.gtop-tech.com/> email: sales@gtop-tech.com
Copyright© 2007 GlobalTop Tech Inc. All right reserved.



FGPMMOPA2 Datasheet

Rev.A07

ESD Handling



Please carefully follow the following precautions to prevent severe damage to GPS modules.

GlobalTop GPS modules are sensitive to electrostatic discharges, and thus are Electrostatic Sensitive Devices (ESD). Careful handling of the GPS modules and in particular to its patch antenna (if included) and RF_IN pin or connector, must follow the standard ESD safety practices:

- ✓ Unless there is a galvanic coupling between the local GND and the PCB GND, then the first point of contact when handling the PCB shall always be between the local GND and PCB GND.
- ✓ Before working with RF_IN pin or connector, please make sure the GND is connected
- ✓ When working with RF_IN pin or connector, do not contact any charges capacitors or materials that can easily develop or store charges such as patch antenna, coax cable, soldering iron.
- ✓ Please do not touch the mounted patch antenna to prevent electrostatic discharge from the RF input.

The document is the exclusive property of GlobalTop Tech Inc. and should not be distributed, reproduced, or any other format without prior permission of GlobalTop Tech Inc. Specifications subject to change without prior notice

GlobalTop Tech Inc.

No.16 Nan-ke 9th Rd, Science-Based Industrial Park, Tainan, 741, Taiwan, R.O.C.
Tel:+886-6-5051268 Fax:+886-6-5053381 <http://www.gtop-tech.com/> email: sales@gtop-tech.com
Copyright© 2007 GlobalTop Tech Inc. All right reserved.

Appendix a

H125-06-GP .049" (1.25mm) Pitch Wire to Board Connector

Manufacturer: CHU YUEN ELECTRONIC CO., LTD.

Ps. This Connector is not included in this product.

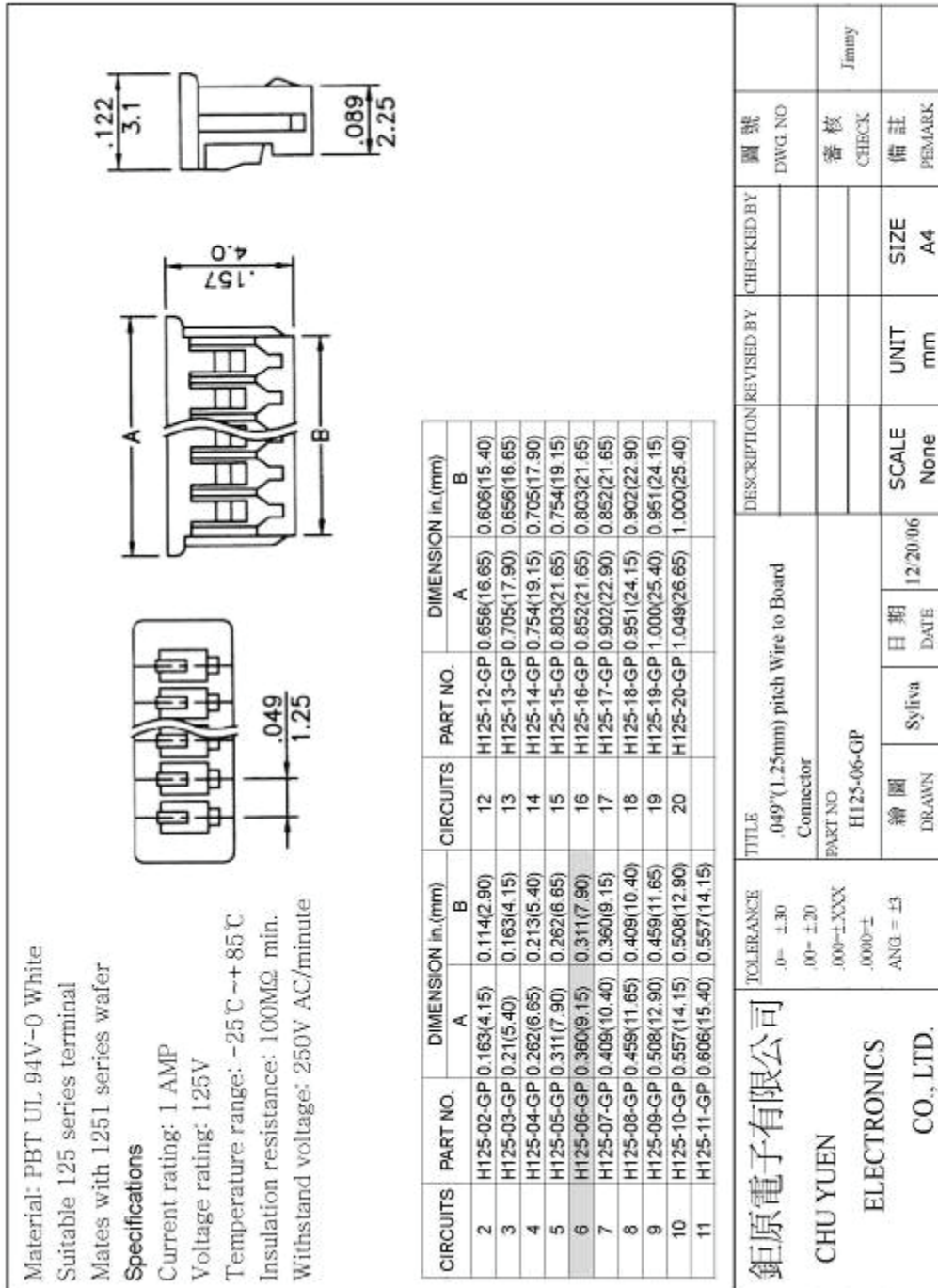

The document is the exclusive property of GlobalTop Tech Inc. and should not be distributed, reproduced, or any other format without prior permission of GlobalTop Tech Inc. Specifications subject to change without prior notice

GlobalTop Tech Inc.

No.16 Nan-ke 9th Rd, Science-Based Industrial Park, Tainan, 741, Taiwan, R.O.C.
 Tel:+886-6-5051268 Fax:+886-6-5053381 <http://www.gtop-tech.com/> email: sales@gtop-tech.com
 Copyright© 2007 GlobalTop Tech Inc. All right reserved.



FGPMMOPA2 Datasheet

Rev.A07

HS125-062 .Single Row Pitch 1.25mm Wire-to-Board Housing H=3.95mm

Manufacturer: HOJAR PRECISION Co.; LTD. (<http://www.hojar.com.tw/>)

Ps. This Connector is not included in this product.

PAGE 5

VERSION
A

Poles	Dimension mm (in.)		Note.
	A	B	
2	1.25(0.049)	4.25(0.167)	
3	2.50(0.098)	5.50(0.217)	
4	3.75(0.148)	6.75(0.266)	
5	5.00(0.197)	8.00(0.315)	
6	6.25(0.246)	9.25(0.364)	
7	7.50(0.295)	10.50(0.413)	
8	8.75(0.344)	11.75(0.463)	
9	10.00(0.394)	13.00(0.512)	
10	11.25(0.443)	14.25(0.561)	
11	12.50(0.492)	15.50(0.610)	
12	13.75(0.541)	16.75(0.659)	
13	15.00(0.591)	18.00(0.709)	
14	16.25(0.640)	19.25(0.758)	
15	17.50(0.689)	20.50(0.807)	

GENERAL TOLERANCE	DRAW	2006/01/20	PART NO	HS125-XX2
X ± 0.5	DATE	H. D. LI		
.XX ± 0.1	DESIGN	H. D. LI	TITLE	Single Row Wire-to-Board Housing
	CHECKED	Y. M. LIU		
	APPROVED	J. F. KANG		
UNIT mm				

The document is the exclusive property of GlobalTop Tech Inc. and should not be distributed, reproduced, or any other format without prior permission of GlobalTop Tech Inc. Specifications subject to change without prior notice

GlobalTop Tech Inc.

No.16 Nan-ke 9th Rd, Science-Based Industrial Park, Tainan, 741, Taiwan, R.O.C.
 Tel:+886-6-5051268 Fax:+886-6-5053381 <http://www.gtop-tech.com/> email: sales@gtop-tech.com
 Copyright© 2007 GlobalTop Tech Inc. All right reserved.

Appendix b

FH3M215-206-GB, Female Header 1.27*1.27 SMT Type H=2.15mm

Manufacturer: CHU YUEN ELECTRONIC CO., LTD.

Ps. This Connector is not included in this product.

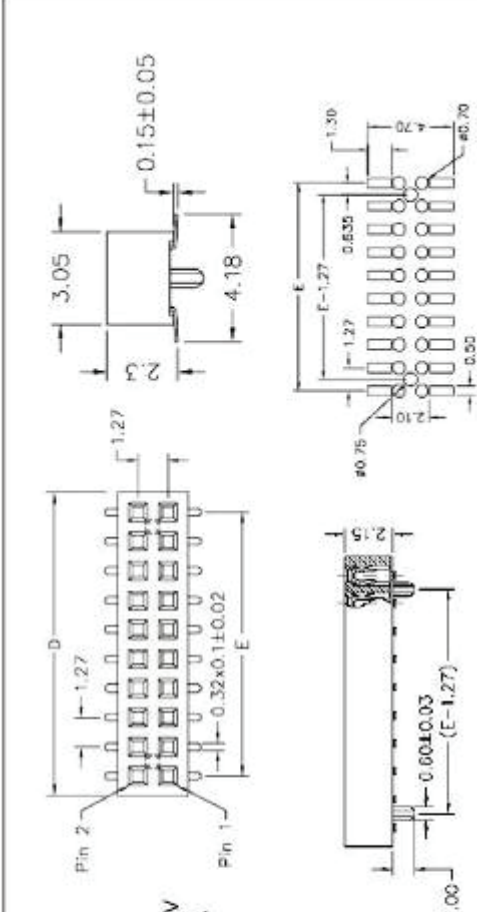

MATERIAL
Insulator : NYLON 6T or 9T
Contact Pin : Brass

SPECIFICATION
Current Rate : 1AMP
Insulation Resistance : 5000M Ω Min at DC 500V
Contact Resistance : 20m Ω Max. at DC 100mA
Operation Temperature : -40 $^{\circ}$ C to +105 $^{\circ}$ C

FH3M215-206-GB-内柱-LF
1, 2, 3, 4, 5, 6, 7, 8

1. 3 : pitch=1.27mm
2. M : SMT
3. H=2.15mm
4. 2: Dual rows
5. Contact of number
6. G : Gold flash
7. B : Black Insulator
8. LF : Lead Free

Pin	1	2	3	4	5	6	7	8	9	10	11	12	13	14	15	16	17	18	19	20	21	22	23	24	25	26	27	28	29	30	31	32	33	34	35	36
Pin	1	2	3	4	5	6	7	8	9	10	11	12	13	14	15	16	17	18	19	20	21	22	23	24	25	26	27	28	29	30	31	32	33	34	35	36
Pin	1	2	3	4	5	6	7	8	9	10	11	12	13	14	15	16	17	18	19	20	21	22	23	24	25	26	27	28	29	30	31	32	33	34	35	36

Recommended P.C.B Layout

鉅原電子有限公司
CHU YUEN ELECTRONICS CO., LTD.

圖號 DWG. NO
審核 CHECK
備註 REMARK

繪圖 Sylvania
日期 DATE: 20/12/06

DESCRIPTION/REVISED BY
Female Header 1.27*1.27 SMT Type H=2.15mm
PART NO FH3M215-206-GB-内柱-LF

圖號 DWG. NO
審核 CHECK
備註 REMARK

The document is the exclusive property of GlobalTop Tech Inc. and should not be distributed, reproduced, or any other format without prior permission of GlobalTop Tech Inc. Specifications subject to change without prior notice

GlobalTop Tech Inc.

No.16 Nan-ke 9th Rd, Science-Based Industrial Park, Tainan, 741, Taiwan, R.O.C.
Tel:+886-6-5051268 Fax:+886-6-5053381 <http://www.gtop-tech.com/> email: sales@gtop-tech.com
Copyright© 2007 GlobalTop Tech Inc. All right reserved.